



# Utility Engineering Consultants, LLC

Phone : 205.951.3838  
FAX : 205.951.3839  
WEB : www.uecllc.com

130 Southcrest Drive, Suite 100  
Homewood, AL 35209  
P.O. Box 19218  
Birmingham, Alabama 35219

May 26, 2021

City of Marion  
123 E. Jefferson Street  
Marion, AL 36756

**RE: ADDENDUM NO. 1  
MARION WASTEWATER TREATMENT IMPROVEMENT PLANT PROJECT  
PHASE I – CONTRACT “A”  
CDBG PROJECT NO. LR-CM-PF-19-006  
CONTRACT NO. MA20 043A**

## ADDENDUM NO. 1

The changes, modifications and/or additions covered by and set forth in this Addendum No. 1 shall become part of and be incorporated in the Specifications, Contract Documents and Bid Documents for the above referenced project.

## CONTRACT DOCUMENTS AND SPECIFICATIONS

### CLARIFICATIONS

- Bypass Connection Detail shall be added to the plans.
- The enclosures and pumps shall be sized for 230V and three phase power.

## SPECIFICATIONS AND CONTRACT DOCUMENTS

- Prebid Notes and Sign In sheet shall be part of Addendum No. 1 (See Attached)

This Addendum No. 1 shall be made a part of your set of Construction Contract Documents and Specifications. Acknowledgment of receipt of Addendum No. 1 shall be noted on Page 10 of the Bid for Unit Price Contract Form.

UTILITY ENGINEERING CONSULTANTS, LLC

Roderick A. Hawkins, P.E.

RAH/dsj

**Attached: Pre-Bid Agenda Notes  
Pre-Bid Sign-In-Sheet  
CDBG Information Packet  
Bypass Connection Detail**

WATER/WASTEWATER/GAS DESIGN \* OPERATOR TRAINING

## **PRE-BID NOTES**

**The City Marion, Alabama  
Marion Wastewater Treatment Improvements Project  
Phase I – Contract “A”  
Contract No. MA20 043  
CDBG Project No. LR-CM-PF-19-006**

**Location: Marion City Hall  
123 E. Jefferson Street, Marion, AL 36756**

**Date: May 25, 2021 @ 10:00 A.M.**

- Introduction of Attendees
- Project Description
  - a. Furnish and Install Two Submersible Pumps at the Marion WWTP Influent Pump Station
  - b. Provide Temporary Bypass Pumping
  - c. Clean Up, Erosion Control and Seeding
- The Project is a CDBG Funded Project
- Bid opening date is June 4, 2021 at 10:00 A.M. at the Marion City Hall
- General Bid Procedures
  - a. All Bid Documents must be enclosed in a sealed opaque envelope. The Project Name, Contractor Name, Alabama Contractor’s License Number; and CDBG Project Number must be shown on the outside of the envelope. The Technical Specification Document do not have to be part of the Bid Document. Please submit only the documents that are enclosed in your “Bid Packet” that’s provided from our office.
  - b. If the Bid Documents are mailed, send the sealed envelope, (noted above) in a mailing package clearly labeled with the project name and noting “Bid Enclosed”. Please allow adequate shipping time to get the documents delivered to Marion.
  - c. Awarding of the contract will be based on contractor experience, availability to start in a timely manner and the contractors bid amount.
  - d. The Owner reserves the right to waive any informalities or to reject any or all bids.
- Contract will be awarded as soon as approval has been received from the City of Marion and the AI Department of Economic and Community Affairs (ADECA).
- Contract with Low Responsive Bidder has to be signed with the City of Marion.
- Davis-Bacon Act Wage Rates must be followed.
- Contractors must show “Good Faith” effort for DBE/WBE participation.
- Notice to Proceed will be provided to the responsive bidder once contracts have been executed.
- Contract time is 60 Calendar Days. Start time for the Contract will be based on anticipated delivery dates of equipment.

- Pre-Bid Notes and Sign-In Sheet will be sent out in Addendum #1 and future Addenda will be sent out as required.
- Ms. Brandy Wilkerson with the Alabama Tombigbee Regional Commission provided a Summary of Administration Requirements.
- A Site Visit was made to the Plant.
- There will be a permanent Bypass Fitting installed somewhere in the general vicinity outside of the Pump Station gate. The detail will be provided with Addendum No. 1



**Utility  
Engineering  
Consultants, LLC**  
WATER WASTEWATER GAS DESIGN • OPERATOR TRAINING

PREBID CONFERENCE  
SIGN IN SHEET

THE CITY MARION, ALABAMA  
MARION WASTEWATER TREATMENT IMPROVEMENTS PROJECT  
PHASE I - CONTRACT "A"

MARION CITY HALL  
123 E. JEFFERSON STREET, MARION, AL 36756  
MAY 25, 2021 @ 10:00 A.M.

CONTRACT NO. MA20 043      CDBG PROJECT NO. LR-CM-PF-19-006

NAME	COMPANY	PHONE	EMAIL ADDRESS
ROD HAMMERS	UEC	205-951-3838	rhamkins@uec.com
[Signature]	City of Marion, AL	334-683-6545	whinton@cityofmarion.al.org
[Signature]	City of Marion	(334) 683-6545	tsmith@cityofmarion.org
Brandy Wilkerson	AT&T	334-683-7234	brandy.wilkerson@att.net
PAUL SMELLEY	DOUBLE DIAMOND	205-657-4475	PAUL@DOUBLEDIAMOND.CO.COM
Bonnie Fraile	Goldman Contractors	205 652 1616	gc@goldmancontractors.com

**Important CDBG related information in this packet regarding:**

**-Section 3 Information**

**-Goals for Minority and  
Females**

**-Wage Decision**

**Please contact me with any questions:**

**Brandy Wilkerson  
Planning Director  
Alabama Tombigbee Regional Commission  
107 Broad Street  
Camden, AL 36726  
Phone: 334-682-4234  
Fax: 334-682-4205  
Email: [brandy.wilkerson@atrc.net](mailto:brandy.wilkerson@atrc.net)**

### **What is Section 3?**

Section 3 is a provision of the Housing and Urban Development Act of 1968. The purpose of Section 3 is to ensure that employment and other economic opportunities generated by certain HUD financial assistance shall, to the greatest extent feasible, and consistent with existing Federal, State and local laws and regulations, be directed to low- and very low income persons, particularly those who are recipients of government assistance for housing, and to business concerns which provide economic opportunities to low- and very low-income persons.

### **What does To the Greatest Extent Feasible Mean?**

By to the Greatest Extent Feasible, the Department means the every effort must be made to comply with the regulatory requirements of Section 3. By this, the Department means that recipients of Section 3 covered financial assistance should make every effort within their disposal to meet the regulatory requirements. For instance, this may mean going a step beyond normal notification procedures for employment and contracting procedures by developing strategies that will specifically target Section 3 residents and businesses for these types of economic opportunities.

**What does the term Section 3 resident mean?** A section 3 resident is: 1) a public housing resident; or 2) a low- or very low income person residing in the metropolitan area or non-metropolitan county where the Section 3 covered assistance is expended.

### **What is a Section 3 covered project?**

A Section 3 covered project involves the construction or rehabilitation of housing (including reduction of lead-based paint hazards), or other public construction such as street repair, sewage line repair or installation, updates to building facades, etc.

### **What responsibilities do contractors/subcontractors have if they receive Section 3 covered contracts?**

If the contractor/subcontractor has the need to hire new persons to complete the Section 3 covered contract or needs to subcontract portions of the work to another business, they are required to direct their newly created employment and/or subcontracting opportunities to Section 3 residents and business concerns. The same numerical goals apply to contractors and subcontractors (i.e., 30 percent of new hires, 10 percent of construction contracts, and 3 percent of non-construction contracts). In addition, the contractor/subcontractor must notify the recipient agency about their efforts to comply with Section 3 and submit any required documentation.

### **What is a new hire?**

A new hire means a full-time employee for a new permanent, temporary, or seasonal position that is created as a direct result of the expenditure of Section 3 covered financial assistance.

### **What does the term Section 3 Business Concern mean?**

Section 3 business concerns are businesses that can provide evidence that they meet one of the following criteria: a) 51 percent or more owned by Section 3 residents; or b) At least 30 percent of its full time employees include persons that are currently Section 3 residents, or were Section 3 residents within three years of the date of first hire\*; or c) Provides evidence, as required, of a commitment to

subcontract in excess of 25 percent of the dollar award of all subcontracts to business concerns that meet one of the first two qualifications above.

**\*Example:** Alysha was an unemployed Section 3 resident that was first hired by ABC Company on January 1, 2011. She received a raise of \$2,500 in March 2012, thereby boosting her household income above the local low income level. ABC Company may continue to count Alysha as one of their Section 3 employees until December 31, 2013 (i.e. within three years of the date of first hire).

**What dollar threshold amounts apply to contractors/subcontractors?**

All contracts (or subcontracts) funded with Public and Indian Housing assistance, regardless of dollar amount or type of contract, is subject to the requirements of Section 3. With respect to recipients of Housing and/or Community Development funding, all contractors or subcontractors that receive covered contracts in excess of \$100,000 for housing construction, rehabilitation, or other public construction are required to comply with the requirements of Section 3.

**How does Section 3 differ from the Minority Business Enterprise/Women Business Enterprise programs?**

Section 3 is both race and gender neutral. The preferences provided under this regulation are based on income-level and location. Section 3 regulations were designed to encourage recipients of HUD funding to direct new employment, training, and contracting opportunities to low-income residents, and the businesses that employ these persons, within their community regardless of race and/or gender. To learn more about the Minority Business Enterprise and Women Business Enterprise programs, please contact HUD's Office of Small and Disadvantaged Business Utilization at 202-708-1428, or visit their website, located at: [http://portal.hud.gov/portal/page/portal/HUD/program\\_offices/sdb](http://portal.hud.gov/portal/page/portal/HUD/program_offices/sdb).

## Goals for Female and Minority Participation

The goals & timetables for minority & female participation, expressed in percentage terms for the Contractors aggregate workforce in each trade on all construction work in the covered area are as follows:

<u>Female</u>		
<u>Area Covered - Statewide</u>		
Time Table	Trade	Goals %
Until Further		
Notice	All	6.9%

<u>Minority</u>		
<u>Area Covered - Jefferson, Shelby, &amp; Walker Counties</u>		
Time Table	Trade	Goals %
Until Further		
Notice	All	24.9

<u>Area Covered – Mobile &amp; Baldwin Counties</u>		
Time Table	Trade	Goals %
Until Further		
Notice	All	25.9

<u>Area Covered - Choctaw, Clarke, Conecuh, Escambia, Monroe, Marengo Washington, &amp; Wilcox Counties</u>		
Time Table	Trade	Goals %
Until Further		
Notice	All	26.4

<u>Area Covered – Montgomery, Autauga, Elmore, Barbour, Bullock, Butler, Coffee, Coosa, Covington, Crenshaw, Dale, Dallas, Geneva, Henry, Houston, Lowndes, Macon, Perry, Pike, &amp; Tallapoosa Counties</u>		
Time Table	Trade	Goals %
Until Further		
Notice	All	29.9

<u>Area Covered – Calhoun County</u>		
Time Table	Trade	Goals %
Until Further		
Notice	All	14.3

<u>Area Covered - St. Clair &amp; Etowah Counties</u>		
Time Table	Trade	Goals %
Until Further		
Notice	All	24.9

<u>Area Covered - Tuscaloosa County</u>		
Time Table	Trade	Goals %
Until Further		
Notice	All	20.6

<u>Area Covered – Bibb, Blount, Cherokee, Chilton, Clay Cleburne, Cullman, Fayette, Greene, Hale, Lamar, Marion, Pickens, Randolph, Sumter, Talladega, &amp; Winston Counties</u>		
Time Table	Trade	Goals %
Until Further		
Notice	All	20.7

<u>Area Covered - Russell County</u>		
Time Table	Trade	Goals %
Until Further		
Notice	All	29.6

<u>Area Covered – Colbert and Lauderdale Counties</u>		
Time Table	Trade	Goals %
Until Further		
Notice	All	11.9

<u>Area Covered - Limestone, Madison And Marshall Counties</u>		
Time Table	Trade	Goals%
Until Further		
Notice	All	12.0

<u>Area Covered - Franklin, Lawrence, and Morgan Counties</u>		
Time Table	Trade	Goals%
Until Further		
Notice	All	11.2

<u>Area Covered - Chambers and Lee Counties</u>		
Time Table	Trade	Goals%
Until Further		
Notice	All	31.6

<u>Area Covered - DeKalb and Jackson Counties</u>		
Time Table	Trade	Goals%
Until Further		
Notice	All	8.6



"General Decision Number: AL20210070 01/01/2021

Superseded General Decision Number: AL20200070

**REMEMBER**

State: Alabama

**\*Workers must be paid on a weekly basis.**

Construction Type: Heavy  
Including Water and Sewer Line Construction

**\*Workers working over 40 hours a week must be paid time and a half for any hours over 40.**

Counties: Choctaw, Clarke, Conecuh, Escambia, Marengo, Monroe, Perry, Sumter, Washington and Wilcox Counties in Alabama.

**\*Workers' hourly rate must be at least the wage associated with their classification.**

Note: Under Executive Order (EO) 13658, an hourly minimum wage of \$10.95 for calendar year 2021 applies to all contracts subject to the Davis-Bacon Act for which the contract is awarded (and any solicitation was issued) on or after January 1, 2015. If this contract is covered by the EO, the contractor must pay all workers in any classification listed on this wage determination at least \$10.95 per hour (or the applicable wage rate listed on this wage determination, if it is higher) for all hours spent performing on the contract in calendar year 2021. If this contract is covered by the EO and a classification considered necessary for performance of work on the contract does not appear on this wage determination, the contractor must pay workers in that classification at least the wage rate determined through the conformance process set forth in 29 CFR 5.5(a)(1)(ii) (or the EO minimum wage rate, if it is higher than the conformed wage rate). The EO minimum wage rate will be adjusted annually. Please note that this EO applies to the above-mentioned types of contracts entered into by the federal government that are subject to the Davis-Bacon Act itself, but it does not apply to contracts subject only to the Davis-Bacon Related Acts, including those set forth at 29 CFR 5.1(a)(2)-(60). Additional information on contractor requirements and worker protections under the EO is available at [www.dol.gov/whd/govcontracts](http://www.dol.gov/whd/govcontracts).

**\*Weekly certified payrolls are required.**

**\*HUD 11s will be conducted on the job site.**

Modification Number      Publication Date  
0                              01/01/2021

ENGI0312-010 09/01/2011

PERRY and SUMTER COUNTY

	Rates	Fringes
Operating Engineers:		
Crane and Cherry Picker.....	\$ 25.90	10.65
Oiler.....	\$ 22.83	10.65

Cranes with 100 ft. or more boom receive \$0.25 extra per hour,  
Cranes with 200 ft. or more boom receive \$0.50 extra per hour,  
Cranes with 350 ft. or more boom receive \$1.10 extra per hour,  
Cranes with 500 ft. or more boom receive \$1.45 extra per hour,  
Tower Cranes, Derricks, Climbing Cranes, Ringer Cranes shall

receive \$0.35 in addition to A-rate and boom pay per hour

-----  
\* ENGI0653-007 10/01/2016

CHOCTAW, CLARKE, CONECH, ESCAMBIA, MARENGO, MONROE,  
WASHINGTON, and WILCOX COUNTIES

	Rates	Fringes
Operating Engineers:		
Crane (Conventional & Hydraulic 100 to 400 Tons), and Tower Cranes.....	\$ 28.30	12.08
Crane (Conventional & Hydraulic up to 100 Tons), and Derrick (Stationary Crane with 2 or more drums).	\$ 27.30	12.08
Cranes with 350 feet or more boom and/or 400 to 600 ton capacity.....	\$ 29.40	12.08
Cranes with 500 feet Boom and/or 600 ton capacity.....	\$ 29.75	12.08
Oiler.....	\$ 25.45	12.08

-----  
SUAL2007-155 11/28/2007

	Rates	Fringes
BOILERMAKER.....	\$ 21.85	9.24
ELECTRICIAN.....	\$ 15.24	2.50
LABORER: Common or General.....	\$ 7.63	0.00
LABORER: Pipelayer.....	\$ 9.96	0.00
OPERATOR: Backhoe.....	\$ 12.00	0.00
OPERATOR: Bulldozer.....	\$ 18.89	0.00
OPERATOR: Drill.....	\$ 9.50	2.36
OPERATOR: Grader/Blade.....	\$ 12.59	1.33
OPERATOR: Loader (Front End)....	\$ 11.67	0.00
OPERATOR: Roller.....	\$ 9.45	0.00
OPERATOR: Scraper.....	\$ 9.78	0.18
OPERATOR: Trackhoe.....	\$ 12.00	0.00
TRUCK DRIVER.....	\$ 10.65	1.36

-----  
WELDERS - Receive rate prescribed for craft performing operation to which welding is incidental.

=====  
Note: Executive Order (EO) 13706, Establishing Paid Sick Leave for Federal Contractors applies to all contracts subject to the Davis-Bacon Act for which the contract is awarded (and any

solicitation was issued) on or after January 1, 2017. If this contract is covered by the EO, the contractor must provide employees with 1 hour of paid sick leave for every 30 hours they work, up to 56 hours of paid sick leave each year. Employees must be permitted to use paid sick leave for their own illness, injury or other health-related needs, including preventive care; to assist a family member (or person who is like family to the employee) who is ill, injured, or has other health-related needs, including preventive care; or for reasons resulting from, or to assist a family member (or person who is like family to the employee) who is a victim of, domestic violence, sexual assault, or stalking. Additional information on contractor requirements and worker protections under the EO is available at [www.dol.gov/whd/govcontracts](http://www.dol.gov/whd/govcontracts).

Unlisted classifications needed for work not included within the scope of the classifications listed may be added after award only as provided in the labor standards contract clauses (29CFR 5.5 (a) (1) (ii)).

-----

The body of each wage determination lists the classification and wage rates that have been found to be prevailing for the cited type(s) of construction in the area covered by the wage determination. The classifications are listed in alphabetical order of "identifiers" that indicate whether the particular rate is a union rate (current union negotiated rate for local), a survey rate (weighted average rate) or a union average rate (weighted union average rate).

#### Union Rate Identifiers

A four letter classification abbreviation identifier enclosed in dotted lines beginning with characters other than "SU" or "UAVG" denotes that the union classification and rate were prevailing for that classification in the survey. Example: PLUM0198-005 07/01/2014. PLUM is an abbreviation identifier of the union which prevailed in the survey for this classification, which in this example would be Plumbers. 0198 indicates the local union number or district council number where applicable, i.e., Plumbers Local 0198. The next number, 005 in the example, is an internal number used in processing the wage determination. 07/01/2014 is the effective date of the most current negotiated rate, which in this example is July 1, 2014.

Union prevailing wage rates are updated to reflect all rate changes in the collective bargaining agreement (CBA) governing this classification and rate.

#### Survey Rate Identifiers

Classifications listed under the "SU" identifier indicate that no one rate prevailed for this classification in the survey and the published rate is derived by computing a weighted average rate based on all the rates reported in the survey for that classification. As this weighted average rate includes all rates reported in the survey, it may include both union and non-union rates. Example: SULA2012-007 5/13/2014. SU indicates the rates are survey rates based on a weighted average calculation of rates and are not majority rates. LA indicates the State of Louisiana. 2012 is the year of survey on which

these classifications and rates are based. The next number, 007 in the example, is an internal number used in producing the wage determination. 5/13/2014 indicates the survey completion date for the classifications and rates under that identifier.

Survey wage rates are not updated and remain in effect until a new survey is conducted.

#### Union Average Rate Identifiers

Classification(s) listed under the UAVG identifier indicate that no single majority rate prevailed for those classifications; however, 100% of the data reported for the classifications was union data. EXAMPLE: UAVG-OH-0010 08/29/2014. UAVG indicates that the rate is a weighted union average rate. OH indicates the state. The next number, 0010 in the example, is an internal number used in producing the wage determination. 08/29/2014 indicates the survey completion date for the classifications and rates under that identifier.

A UAVG rate will be updated once a year, usually in January of each year, to reflect a weighted average of the current negotiated/CBA rate of the union locals from which the rate is based.

---

#### WAGE DETERMINATION APPEALS PROCESS

1.) Has there been an initial decision in the matter? This can be:

- \* an existing published wage determination
- \* a survey underlying a wage determination
- \* a Wage and Hour Division letter setting forth a position on a wage determination matter
- \* a conformance (additional classification and rate) ruling

On survey related matters, initial contact, including requests for summaries of surveys, should be with the Wage and Hour Regional Office for the area in which the survey was conducted because those Regional Offices have responsibility for the Davis-Bacon survey program. If the response from this initial contact is not satisfactory, then the process described in 2.) and 3.) should be followed.

With regard to any other matter not yet ripe for the formal process described here, initial contact should be with the Branch of Construction Wage Determinations. Write to:

Branch of Construction Wage Determinations  
Wage and Hour Division  
U.S. Department of Labor  
200 Constitution Avenue, N.W.  
Washington, DC 20210

2.) If the answer to the question in 1.) is yes, then an interested party (those affected by the action) can request review and reconsideration from the Wage and Hour Administrator (See 29 CFR Part 1.8 and 29 CFR Part 7). Write to:

Wage and Hour Administrator  
U.S. Department of Labor

200 Constitution Avenue, N.W.  
Washington, DC 20210

The request should be accompanied by a full statement of the interested party's position and by any information (wage payment data, project description, area practice material, etc.) that the requestor considers relevant to the issue.

3.) If the decision of the Administrator is not favorable, an interested party may appeal directly to the Administrative Review Board (formerly the Wage Appeals Board). Write to:

Administrative Review Board  
U.S. Department of Labor  
200 Constitution Avenue, N.W.  
Washington, DC 20210

4.) All decisions by the Administrative Review Board are final.

=====

END OF GENERAL DECISION

"

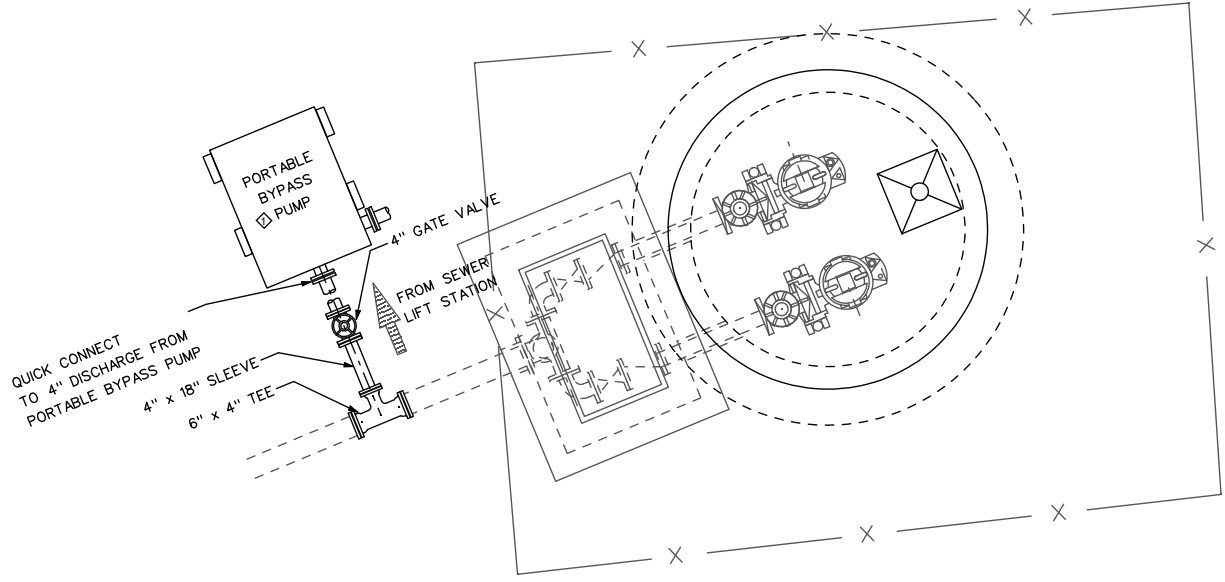

◇ PORTABLE BYPASS CONNECTION DETAIL



NO.	DATE	REMARKS	BY
◇	5/27/21	ADDENDUM NO. 1	RAH
REVISIONS			

THE CITY OF  
**MARION ALABAMA**  
 MARION WASTEWATER TREATMENT PLANT  
 IMPROVEMENTS PROJECT  
 PHASE 1- CONTRACT "A"  
 (INFLUENT LIFT STATION UPGRADES)  
 CDBG PROJECT NO.  
 LR-CM-PF-19-006

**EXISTING INFLUENT PUMP  
 STATION MODIFICATIONS/  
 ELECTRICAL PLAN**

**Utility  
Engineering  
Consultants, LLC**

100 S. GIBSON DRIVE  
FIBER  
HOMERWOOD, ALABAMA 36009

DESIGNED RAH	DRAWN MK	SCALE AS NOTED	DATE MAY, 2021
APPROVED <i>Phil B. [Signature]</i>		REFERENCE LIFTSTATION2.DGN	JOB NO. MA20 043
SHEET 5 OF 6			